

# FISCHBEIN®

## Model 400 HP™

High Performance Plain Sew

## Fischbein Model 400 HP™

The Fischbein Model 400 HP™ is a high-performance plain sew system that sets the industry standard for high-speed bag closing in the most demanding, high volume bagging environments. Safe and easy to use, the Model 400 HP™ is capable of sewing speeds up to 75 linear feet per minute. Features include a pneumatic rotary knife that efficiently cuts the thread at high speeds and an automated infeed system that guides the top of the bag through the entire bag sewing process.



**EVERYTHING** IN BAGGING EQUIPMENT™



# Fischbein® Model 400 HP™

## High Performance Plain Sew

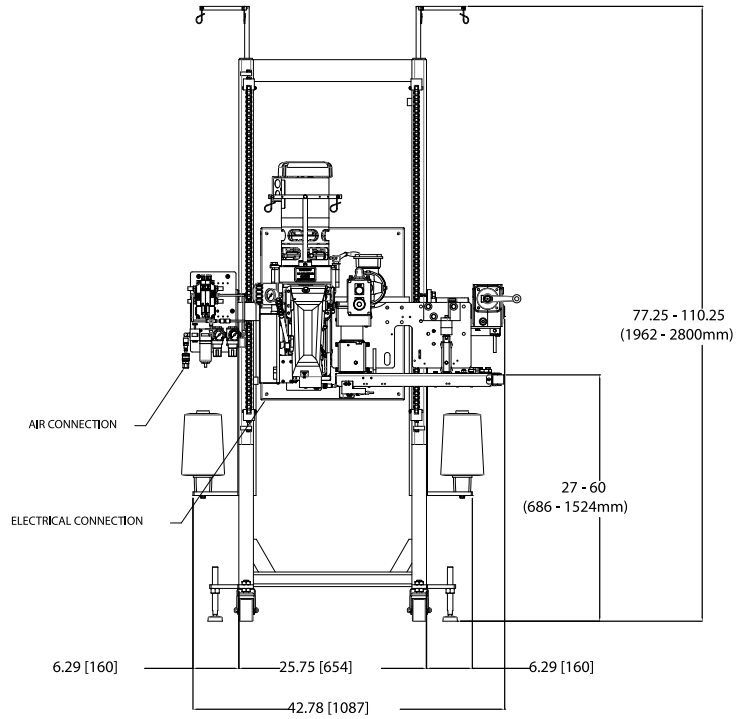
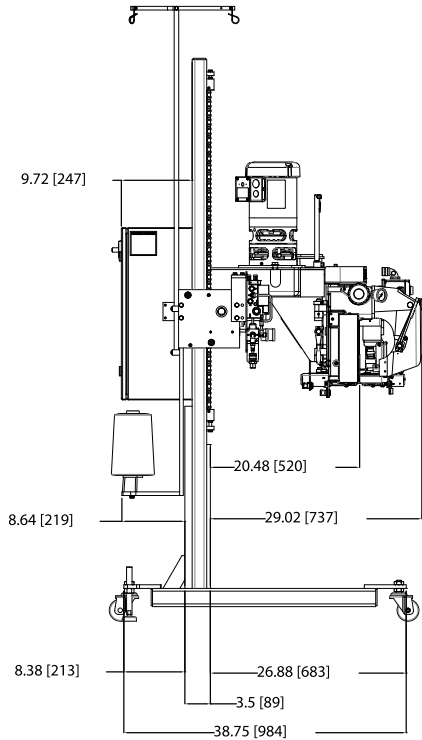

400HP

### FEATURES

#### BAG TYPES

Closes a variety of pillow style or gusseted bags, including multi-wall paper, laminated and non-laminated woven polypropylene, and jute.

#### INFEE SYSTEM

Fast. Safe. Automated. The leading edge of the bag is fed into the infeed, which automatically guides the bag's top through the entire bag sewing process.

#### EMPRESS 200 SEWING HEAD

With its self-lubricating system, the Empress 200 delivers trouble-free, smooth performance with low vibration. Operating speeds up to 75 linear feet per minute.

#### HIGH SPEED ROTARY KNIFE

Pneumatic rotary knife is designed for high speed bag closing applications where efficient thread cutting is critical.

#### SWING FEATURE

Exclusive sewing head swing feature makes threading the 400 HP™ a snap, and provides full access for cleaning and easy head removal.

### OPTIONS

- Direct drive VFD package for synchronous sewing
- Motor starter and contactor for conveyor
- Optical thread break and oil sensor package
- Tagger Infeed
- Rotary knife thread cutter
- 575 VAC

### SPECIFICATIONS

- Dimensions: L 46 in (117 cm), D 41 in (104 cm), H 78 in (198 cm)
- Speed: Up to 75 linear feet per minute
- Electric (NEMA 12): 230/380/460 VAC, 3 PH, 50/60 Hz
- Air: 5 cfm @ 90 PSI

### BAGS

- Bag Types: Multi-wall paper, woven polypropylene bags and jute.
- Bag Thickness: Maximum 12 mils
- Free Bag Top: Minimum 6 in (15.2 cm)

### APPLICATIONS

- Fertilizers/Minerals
- Chemicals
- Cat Litter
- Pet Food
- Feed Additives
- Agricultural Seed
- Bakery Mixes
- Powdered Dairy Products

**704-871-1159**

**HAMER  
FISCHBEIN®**

A DURAVANT COMPANY

Specifications are subject to change without notice.

